



## Highly Integrated 15 Watt LED Driver/Controller

### L Series

The L Series products are highly integrated, constant current driver/controllers for high-brightness LED lighting applications, targeted at in-fixture installation.

The L Series driver/controllers can be used in a network or as standalone devices. ShowMaster, supported on all eldoLED driver/controllers, allows you to upload show sequences for use in standalone mode. Create and manage your own show sequences using the TOOLbox and freely available PC software.

The L Series driver/controllers feature one LED current source for up to 4 LED groups. They are DMX and LedSync compatible, allowing 15-bit dimming and colour control and bidirectional communication for driver configuration and temperature read-out.

### L-Dot Pico

The L-Dot Pico is the ideal choice for powering 350mA - 700mA, high-brightness LEDs and is available in a 1-, 2-, 3- and 4-channel version.

### Single current source, multiple LED colour groups

eldoLED technology drives up to 4 LED (colour) groups from a single, high-precision LED current source, which not only gives the L Series driver/controllers a power efficiency of up to 95% but has also resulted in a break-through form factor.

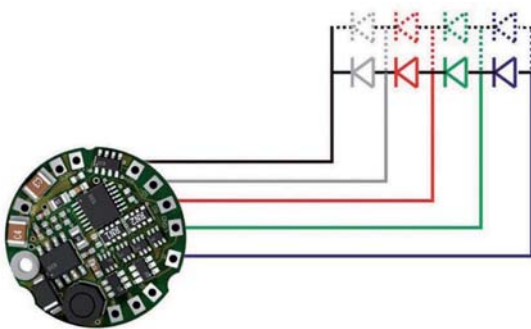

Example of an LED group wiring schematic

### Small form factor: in-fixture installation

The remarkably small size of the driver/controller makes it ideally suited for in-fixture installation, leading to less cabling, increased design freedom and improved system cost for luminaire manufacturers.

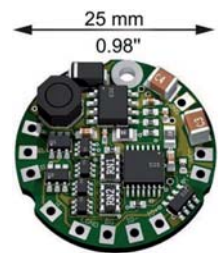

### High control resolution

The L-Dot Pico supports a 15-bit control resolution per output channel for accurate dimming and fine colour mixing.

### Low EMI

Shorter LED wires due to in-fixture installation, slew-rate controlled dimming, shielded conductors and the use of a single LED current source all contribute to keeping the driver's EMI emissions at a very low level.

### Robust thermal management

The L Series' high efficiency results in less heat at the same light output. This means you can have an equal light output from a smaller package - the driver/controller can even share the heat sink of the LED engine, lowering total system costs. Furthermore, its NTC interface enables various ways of thermal protection, including LED throttling, a graceful decrease of light output until normal operating temperatures are reached.

### Features

- USITT DMX512A and LedSync compatible
- Break-through form factor: 25mm / 0.98" diameter
- Power output: up to 15W
- Operating supply voltage range: 12V - 28V DC
- Onboard thermal interface for NTC thermistor

### Advantages

- In-fixture installation
- Accurate, smooth dimming and high-res colour mixing
- Power efficiency of up to 95%
- Drive, control and thermal protection per fixture
- Easy network setup
- Low EMI

**Electrical data**

- LED current settings: up to 700mA (with external resistor)
- Power output range: 0-15W
- Operating supply voltage range: 12V-28V DC
- Efficiency: up to 95%
- Processor: eldoLED FluxLogic 1600 Series
- Independent LED groups: 1, 2, 3 or 4, depending on driver version

**Dynamic effects**

- Hydra Drive Algorithm Based Modulation
- Control of channel 1 (R), 2 (G), 3 (B) and 4 (W/A): 0 - 100% in 15-bit set point resolution
- Contrast ratio: up to 8,000:1

**Thermal data**

- Passive cooling: heat sink mounting. Heat sink for driver only must be able to dissipate 10% of power consumed by LED engine. E.g. If LEDs consume 10W, driver requires a 1W heat sink.
- Built-in protection against overheating

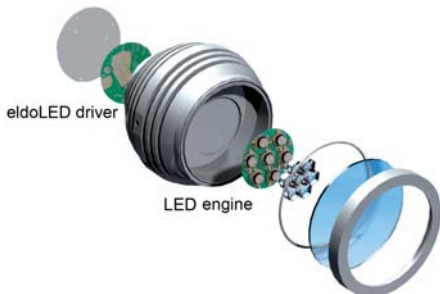

**Thermal data (continued)**

- NTC thermistor interface: for reliable over temperature protection of connected LEDs

**Network control**

- Network input: USITT DMX512A or LedSync, based on RS485 specification
- Input signal update rate: 8ms
- Network resolution: 8 or 16 bit, set at factory or with TOOLbox and PC software
- Network channels used by driver in 8-bit resolution: 1, 2, 3, or 4
- Network channels used by driver in 16-bit resolution: 2, 4, 6 or 8
- Communication: bidirectional for driver configuration and temperature readout
- Start address configuration: with TOOLbox and PC software

**ShowMaster**

- Nine standard shows or up to 20 customer-defined shows set at factory.
- User-defined shows (ShowMaster): up to 20 shows, via TOOLbox and PC software
- Show selection: via TOOLbox and PC software

**Connections**

- Power: solder pads (2)
- Data: solder pads (3)
- NTC thermistor: solder pads (2)

**Connections (continued)**

- LED current setting: solder pads (2)
- LED groups: solder pads (5)

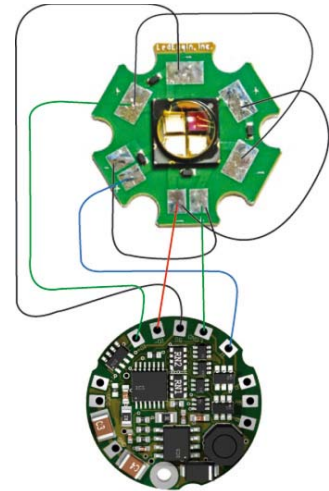

Sample wiring schematic of L-Dot Pico with LedEngine 10W RGB

**Environmental ratings**

- Maximum ambient temperature: 60°C (140°F)
- Minimum ambient temperature: 0°C (32°F)
- Storage ambient temperature: -40°C to 95°C (-40°F to 203°F)
- Relative humidity: non-condensing

**Mounting data**

- Mounting orientation: any
- Mounting hole: for M2 screw (1)

**Dimensions and weight**

- PCB diameter: 25 mm / 0.98"
- Driver height: 4.5 mm / 0.18"
- Weight: 2.5g

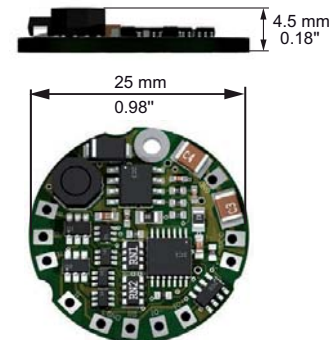

**Ordering information**

Description	Product	Order nr
L-Dot Pico 1 Channel 15W	L-Dot/P 1015	LDP10151
L-Dot Pico 2 Channel 15W	L-Dot/P 2015	LDP20151
L-Dot Pico 3 Channel 15W	L-Dot/P 3015	LDP30151
L-Dot Pico 4 Channel 15W	L-Dot/P 4015	LDP40151